

H10

Manual Flow Control Valve



Function

- Variable orifice, restrictive type, hydraulic flow control, non-pressure compensated. Pressure balanced, bi-directional flow.
- 90 degree rotation.
- Can be used with most of our standard Motorized Flow Control manifold packages

Operating Pressure

- 3000 psi maximum differential
- Consult factory for higher operating pressures

Flow Ranges

- Based on 100 PSI pressure differential with valve fully open.
See pressure drop curves for additional application data
- **03** 0-3 gpm (Equivalent to Ø.14" orifice at full open)
 - **05** 0-5 gpm (Equivalent to Ø.18" orifice at full open)
 - **10** 0-10 gpm (Equivalent to Ø.25" orifice at full open)
 - **15** 0-15 gpm (Equivalent to Ø.31" orifice at full open)
- Custom ranges are available upon request

Construction

- Cage, Body and Spool: Steel, exposed parts plated
- Motor housing assembly: Anodized aluminum
- Standard line bodies are aluminum
- Steel bodies are available upon request

Seal Material

- Buna N and polyurethane standard
- Viton or EPR optional

Internal Leakage

- 1 cubic inch per minute per 1000 psi

Temperature

- -40 to 120°C

Cavity

- C 10-2 industry common cavity

Valve Installation Torque

- 35 ft-lbs

Cartridge Weight

- H10 cartridge only 0.8 lbs
- H10 with aluminum body 1.8 lbs

Seal kit

- SFP25247

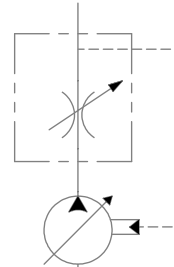

Example Schematic with 10183LS Line Body.

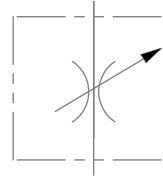

Hydraulic Symbol

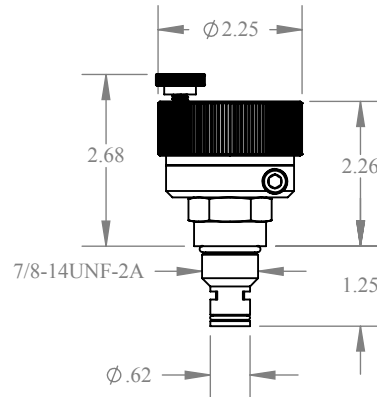

POSITION LOCK SCREW

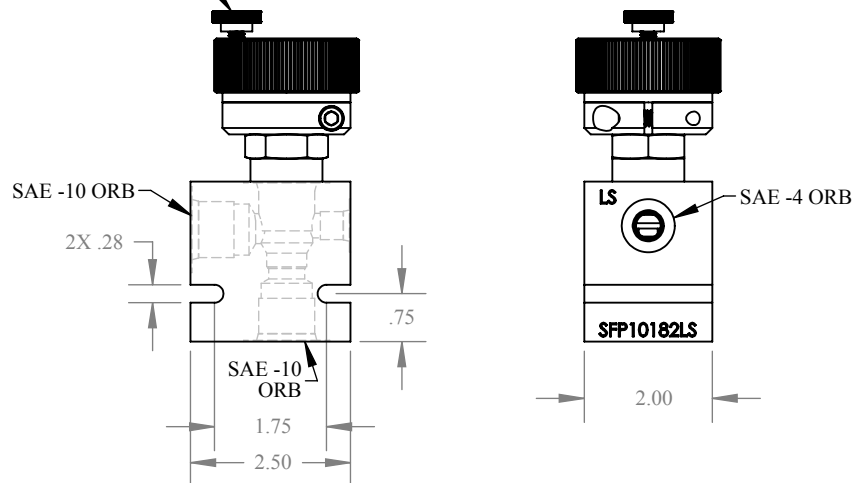

H10

Flow range:

- 03** 0-3 gpm
- 05** 0-5 gpm
- 10** 0-10 gpm
- 15** 0-15 gpm

Line bodies:

- 10182** SAE-8 ports
- 10182LS** SAE-10 ports and SAE-4 LS port