

H20

Manual Flow Control Valve



Function

- Variable orifice, restrictive type, hydraulic flow control, non-pressure compensated. Pressure balanced, bi-directional flow.
- 90 degree rotation.
- Can be used with most of our standard Motorized Flow Control manifold packages

Operating Pressure

- 3000 psi maximum differential
- Consult factory for higher operating pressures

Flow Ranges

Based on 100 PSI pressure differential with valve fully open.
See pressure drop curves for additional application data

- **080** 0-80 gpm (Equivalent to Ø.55" orifice at full open)
- **100** 0-100 gpm (Equivalent to Ø.60" orifice at full open)
- **120** 0-120 gpm (Equivalent to Ø.66" orifice at full open)

Construction

- Cage, Body and Spool: Steel, exposed parts plated
- Motor housing assembly: Anodized aluminum
- Standard line bodies are aluminum
- Steel bodies are available upon request

Seal Material

- Buna N and polyurethane standard
- Viton or EPR optional

Internal Leakage

- 15 cubic inch per minute per 1000 psi

Temperature

- -40 to 120°C

Cavity

- C 20-2 industry common cavity

Valve Installation Torque

- 80 ft-lbs

Cartridge Weight

- H20 cartridge only 1.6 lbs
- H20 with aluminum body 4.9 lbs

Seal kit

- SFP25673

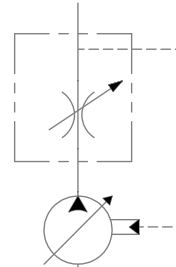

Example Schematic with 10183LS Line Body.

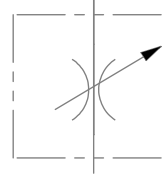

Hydraulic Symbol

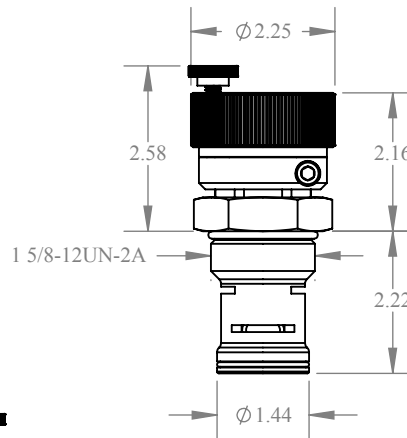

POSITION LOCK SCREW

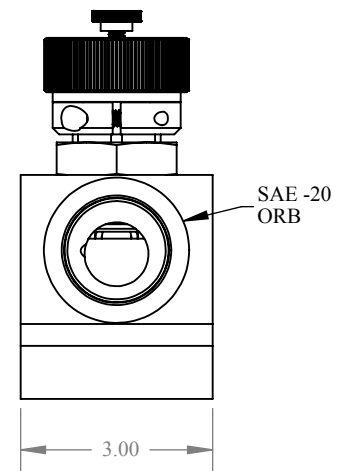
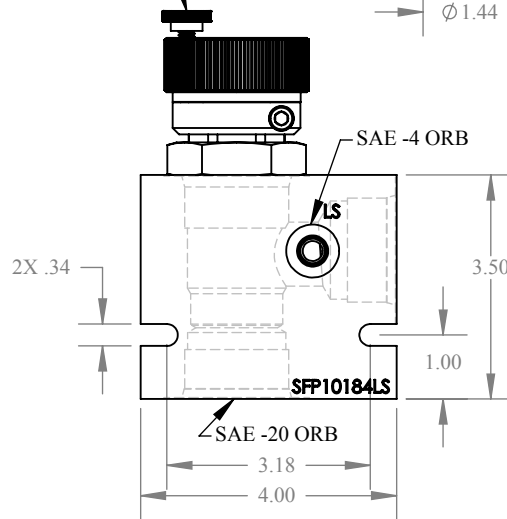

H20

Flow range:
080 0-80 gpm
100 0-100 gpm
120 0-120 gpm

Line bodies:
10184 SAE-16 ports
10184LS SAE-20 ports
 and SAE-4 LS port